

STRONG. VERSATILE. ALL NEW.

GRIZZLY M450e-1100 – THE NEW FORESTRY MULCHER FOR MID-SIZE EXCAVATORS

The brand-new Grizzly M450e-1100 excavator head is a completely new designed forestry mulcher in the class of 15 – 21 t excavators.

It is equipped with a powerful 107 cc hydraulic motor to cover the flow range of the mid-size excavator range and to achieve the best performance for perfect mulching results.

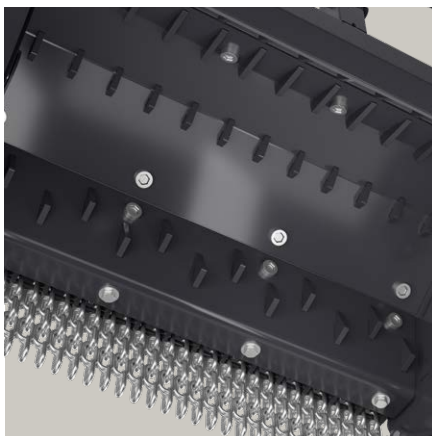

HOUSING

Optimized to make it strong and robust for the forestry application and to allow good access to all the service points. It is covered with bolted liners with counter blades which protect the housing and ensure additional shredding of the material while passing the housing.



PROTECTION FLAP

The optional flap is equipped with counter blades for additional shredding and perfect mulching results. It provides extra protection while mulching next to roads or in residential zones.



THUMB BRACKET

The thumb bracket is available as an option. It enables the easy positioning of the material to be mulched.

Pinotti

STRONG AND VERSATILE

The mulcher can be used universally and is ideal for mulching trees and brush.



MAIN TECHNICAL BENEFITS

- Powerful and high efficiency 107 cc HD- variable displacement motors
- NEW: Power transfer with poly chain – the poly chain system prevents slippage and is low-maintenance
- Hydraulic connections protected inside the housing
- NEW: optional fixed thumb bracket available
- Available with or without flap, electronically or hydraulically controlled (optional)
- Robust design of the push bar for optimum mulching result

TECHNICAL DATA GRIZZLY M450e-1100

Working width	43.3 in (1,100 mm)
Total width (with thumb bracket)	66.1 in (1,680 mm)
Total width (without thumb bracket)	55.0 in (1,398 mm)
Weight*	1,896 – 2,205 lbs (860 – 1,000 kg)
Rotor diameter	17.7 in (450 mm)
Volume flow	32 – 58 gpm (120 – 220 l/min)
Tools	24x BCS or 28x UPTs
Height (without push bar)	35.0 in (890 mm)
Height (with push bar)	37.4 in (950 mm)
Depth (without flap)	30.4 in (773 mm)
Depth (with flap)	31.6 in (802 mm)
Depth (with flap / with push bar)	36.7 in (932 mm)

* Weight depending on the configuration of the machine

Prinoth

1730 N Gault St
St Peter, MN 56082
USA

sales.vm.na@prinoth.com

Prinoth GmbH

Im Branden 15
88634 Herdwangen
GERMANY
Phone +49 7557 92120

prinoth.germany@prinoth.com

Locate your nearest sales and service points at prinoth.com

© 2024. Technical specifications depend on equipment and may vary. Illustrations may contain optional features that do not come as standard. Prinoth reserves the right to make changes and updates at any time without prior notice. Version 07/2024